

AGRAFEUSE TSN 15-864 Q

Pour agrafes G55 / 700/ Q de 32 à 64 mm

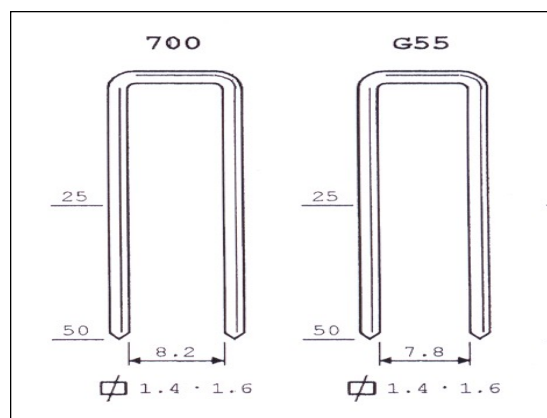

APPLICATIONS

Emballages, caisses, parquet, poutres, lattes, couverture, , cloisons, panneaux, etc...

CARACTÉRISTIQUES

Poids.....2.480 kg
Dimensions (HxLxL) 305 x 86 x 362mm